



# CENTENNIAL

## Plan Benefits Include:

- PROTECTION AGAINST MAJOR SYSTEMS REPAIRS
- 24/7 EMERGENCY ROADSIDE ASSISTANCE
- TOWING
- LOCK OUT SERVICE
- FUEL/FLUID DELIVERY
- BATTERY BOOST
- RENTAL REIMBURSEMENT
- INCREASED RESALE VALUE
- FULLY BACKED

## OPTIONAL COVERAGE

• **Seals and Gaskets:** Seals and gaskets will be covered only if the Seals and Gaskets option is selected at the time of purchase and the appropriate surcharge paid. **Note:** Seepage of seals and gaskets is considered normal wear and tear and is not covered under this Service Contract.

## SURCHARGES

- **4 Wheel/All-Wheel Drive Coverage:** If Your Vehicle is equipped with 4 Wheel/All-Wheel Drive, the following components are covered regardless of the Plan You purchased: 4 Wheel Drive Actuator and Locking Hubs.
- **Diesel:** If You have a diesel Vehicle, an additional mandatory surcharge is applied.
- **1 Ton Vehicle:** If You have a vehicle with a one ton gross weight capacity, (GWC) an additional mandatory surcharge is applied.
- **Turbocharger/Supercharger (factory installed only):** All internal components contained within the Turbocharger/Supercharger Housing, Turbo Boost Valve, Turbo Waste Gate Actuator, Bearing, Bushing, and all other internal components, and Seals and Gaskets, Supply Line.
- **Hybrid/Electric Vehicle:** Electric Motor, Power Controller, Inverter Assembly, Generator, Drive Motor Temperature Sensor/Switch, Battery Cooling Fan Relay/Module, Damper, Electric Water Pump, Electric Air Conditioning Compressor and Battery Cooling Fan, Water Assembly Pump Valve. A mandatory surcharge is applied if Your Vehicle is a hybrid or fully electric model.

Customer Service	800.871.0467
Claims	800.871.0467

Centennial Vehicle Protection is backed by an insurance company that is rated A by A.M. Best

For Inquiries, please contact:



Royal Administrative Services, Inc.  
51 Mill Street, Building F  
Hanover, MA 02339  
PH 800.871.0467  
FAX 781.261.2522  
www.royaladmin.com  
Florida License #60109



CENBR Rev 2.16

**The provider of the service contract in AK, AZ, CA, LA, NV, WA and WI is United Service Protection Corp.**  
**In Florida, the Provider is United Service Protection, Inc., FL. License #60016 - PO Box 20647 St. Petersburg, FL. 33742, 1-800-283-0785**  
**In OK, the provider is Assurant Service Protection Inc,**

This brochure is not a contract. Be sure to read a contract for coverage information, including limitations, exclusions and terms and conditions. Certain Conditions and components are excluded, such as inadequate maintenance of the vehicle, corrosion, and parts designed for limited life such as bulbs, filters and brake pads. See the exclusion section of the service contract for complete details.



# CENTENNIAL



Enjoy Peace of Mind and Complete Powertrain Plus Coverage with the Centennial Plan!

## ADDITIONAL BENEFITS: RENTAL REIMBURSEMENT 24 HOUR EMERGENCY ROADSIDE ASSISTANCE



**AIR CONDITIONING:** Compressor, condenser, evaporator, expansion valve, blower motor. Accumulator/receiver-dryer and orifice tube are covered only if they have failed.

**COOLING:** Water Pump, engine-cooling fan motor, engine-cooling fan and the engine-cooling fan clutch, thermostat.

**ELECTRICAL:** Alternator, voltage regulator, starter motor, starter solenoid, ignition switch, front & rear wiper motors and switches, washer pump and switch, headlamp switch, turn signal switch, rear defroster switch, AC/heater blower speed switch, power window motors, regulators and switches, power door lock actuators and switches.

**ENGINE:** All internal components of the engine that require lubrication for operation are covered. The engine block, Cylinder heads, timing chain cover and oil pan are covered only if damaged by the failure of an internally lubricated engine component.

**4X4 TRANSFER CASE:** All internal components of the transfer case that require lubrication for operation.

**TURBO/SUPERCHARGER:** (Surcharge Required) all internally lubricated parts of the turbocharger or supercharger. Only OEM equipment qualifies for coverage.

**TRANSMISSION:** All internal components of the transmission that require lubrication for operation, including oil pump, drums, planetaries, sun gear and shell, shaft(s), bearings, shift rail, forks, and synchronizers. Torque converter, vacuum modulator, accumulator, electronic shift control unit. Transmission case and pan are covered only if damaged by the failure of an internally lubricated transmission component.

**FUEL SYSTEM:** Fuel pump, fuel injection pump and metal fuel lines.

**DRIVE AXLE (FRONT AND REAR):** All internally lubricated components contained within the drive axle housing. Locking hubs, drive shafts, center support bearings, universal joints, CV joints (except when damaged as a result of a torn or missing CV boot). Drive axle housing and differential cover are covered only if damaged by the failure of an internally lubricated drive axle component.

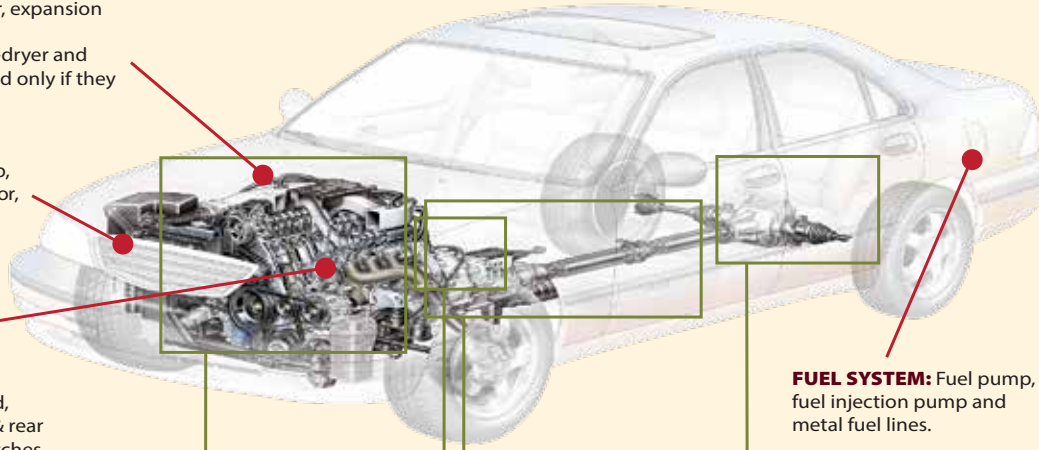

**CENTENNIAL** protects you and your investment against the unexpected repair costs to the Engine, Transmission, Drive Axle and Transfer Case .... costs that are typically the most expensive of all automotive repairs! And because **CENTENNIAL** is a more complete plan, it provides additional mechanical breakdown coverage for the Cooling, Air Conditioning, Fuel and Electrical systems! And because **CENTENNIAL** was designed with you in mind you will also receive 24 Hour Emergency Roadside Assistance and Rental Reimbursement.

**CENTENNIAL is available in a variety of terms to fit most every vehicle and lifestyle.**

Enjoy Peace of  
Mind and  
**Complete  
Powertrain Plus  
Protection**  
with the  
*Centennial Plan!*



Royal Administrative Services, Inc.  
51 Mill Street, Building F  
Hanover, MA 02339  
PH 800.871.0467  
FAX 781.261.2522  
www.royaladmin.com  
Florida License #60109  
In Florida, the Provider is United Service  
Protection, Inc., FL. License #60016

